

115 V_{AC} ICAO Low-intensity, Type A Obstacle Light

Key features

- Based on LED technology
- Extremely reliable - long lifetime
- Very low power consumption
- 115 V AC nominal supply voltage
- Intensity 18 cd typical
- Stabilised light output
- Easy to install
- No RF-radiations
- Safe and easy to use

Benefits

- Long maintenance intervals
- Low energy cost
- Supply power voltage variations do not affect to light output
- Very low total lifetime costs
- Comes with five (5) years warranty

Specifications met

- ICAO International Standards and Recommended Practices:
Aerodromes - Annex 14 Volume 1, 5th Edition, July 2009,
Chapter 6: Low-intensity, Type A Fixed Obstacle Light

Optical characteristics

- Intensity better than 10 cd
- Colour aviation red
- Horizontal radiation pattern 360°
- Vertical radiation pattern 50°
- LED supply current stabilised by constant current generator
- Light output degradation less than 30% after 100.000 h of operation

Electrical characteristics

- LEDs in several separate groups
- Nominal operating voltage 115 V_{AC}
- Power consumption less than 9 VA
- Operating voltage range 105 to 140 V_{AC}
- Internal 115 V_{AC} / 48 V_{DC} power supply
- Two-stage over-voltage protection

Mechanical characteristics

- Yellow ABS+PC body
- Ingress protection IP 30
- Operating temperature range -55°C to +55°C
- Height 100 mm, diameter 92 mm, weight 0,4 kg



Ordering Code: **Obelux 10-115-E27**

Made in Finland

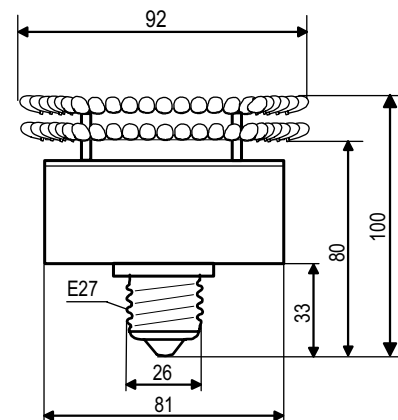

Obelux 10-115-E27



	OPERATING VOLTAGE 115 V_{AC}
	CAUTION ! LED RADIATION DO NOT STARE INTO LED BEAM OR VIEW DIRECTLY WITH OPTICAL INSTRUMENTS. CLASS 2A LED PRODUCT

Technical information in this document is subject to change without notice. Copyright © Obelux Oy 2010