

115 V_{AC} ICAO Low-intensity, Type A Obstacle Light**Key features**

- Extremely reliable - long lifetime
- Very low power consumption
- 115 V_{AC} nominal supply voltage
- Steady burning red light, intensity > 10 cd
- Stabilised light output
- Lightweight and small – low wind load factor
- Easy to install
- Absolutely no RF-radiations

Benefits

- Long maintenance intervals
- Low energy cost
- Supply power voltage variations do not affect to light output
- Very low total lifetime costs
- Low wind load
- Two-stage over-voltage protection
- Easy to chain
- Comes with five (5) years warranty

Specifications met

- ICAO International Standards and Recommended Practices:
Aerodromes - Annex 14 Volume 1, 5th Edition, July 2009,
Chapter 6: Low-intensity, Type A Fixed Obstacle Light

Optical characteristics

- Intensity better than 10 cd
- Colour aviation red
- Horizontal radiation pattern 360°
- Vertical radiation pattern 50°
- LED supply current stabilised by constant current generator
- Light output degradation less than 30% after 100.000 h of operation

Electrical characteristics

- LEDs in separate groups
- Nominal operating voltage 115 V_{AC}
- Power consumption less than 9 VA
- Operating voltage range 110 to 130 V_{AC}

Mechanical characteristics

- Yellow painted aluminium body
- Colourless (clear) glass cover
- Terminal box for 1,5 - 6 mm² wires
- Weather protection to IP 65
- Operating temperature range -55°C ... +55°C
- Height 235 mm, diameter 120 mm, weight 1,1 kg
- Wind load with MS-60 mounting kit @ 200 km/h less than 40 N

Options

- MS-60 Mounting kit
- MS-100 Mounting kit

Ordering Code: **Obelux 10-115-F**

Made in Finland

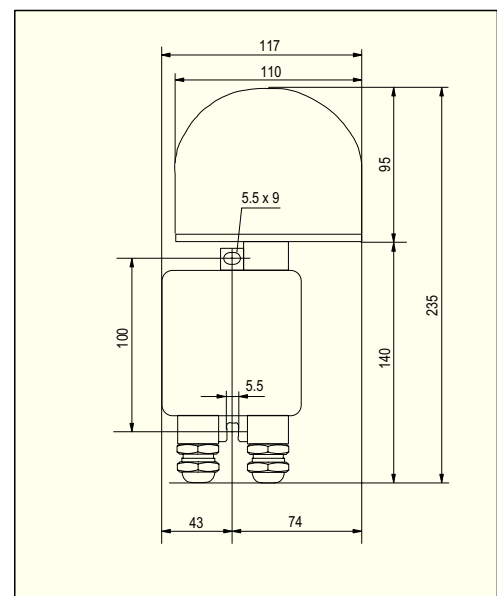
**Obelux 10-115-F****Obelux 10-115-F dimensions**

Technical information in this document is subject to change without notice. Copyright © Obelux Oy 2010

115 V_{AC} ICAO Low-intensity, Type A Obstacle Light

Obelux 10-115-F is an obstacle light utilizing LED technology. The cabling and installation principles are similar to those of conventional obstacle lights.

Connection can be protected with a 6 A or 10 A fuse or with a circuit breaker (C curve).

Technical specifications

- Operating voltage: 115 V_{AC}
- Power consumption: < 9 VA, <6 W
- Current consumption: < 100 mA
- Two-stage overvoltage protection
- Weather protection: IP65
- Operating temperature range: -55...+55 °C
- Height: 235 mm
- Diameter: 120 mm
- Glass cover thickness: 5 mm
- Terminal box: yellow powder painted die cast Aluminium
- Weight: 1.1 kg

Installation specifications

- Cable gland: PG 16
- Cable diameter: 8...14 mm
- Wire diameter: max. 6 mm²
- Recommended cable: 4x1.5+1.5 or 2x1.5+1.5 mm²
- Fixing hole distance: 100 mm
- Fixing screw diameter: max. 5 mm
- Fixing base thickness: 5 mm

Mounting sets

- MS-60: Mounting onto Ø 30...60 mm pipes
- MS-100: Mounting onto Ø 60...100 mm pipes
- U-bolts and hex nuts M8: acid-proof steel
- Mounting plate: black anodized aluminium

Options

- MS-60 Mounting kit
- MS-100 Mounting kit

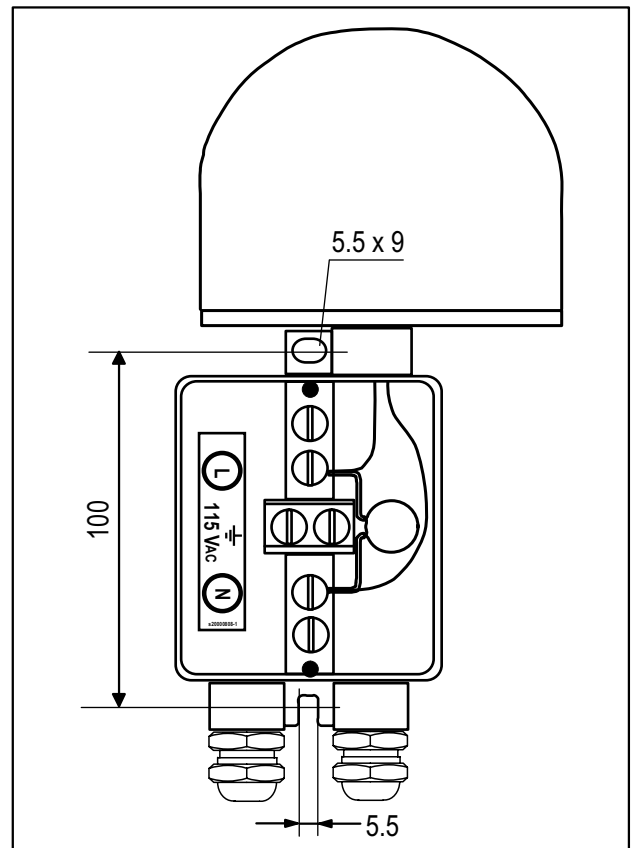

Obelux 10-115-F terminal box

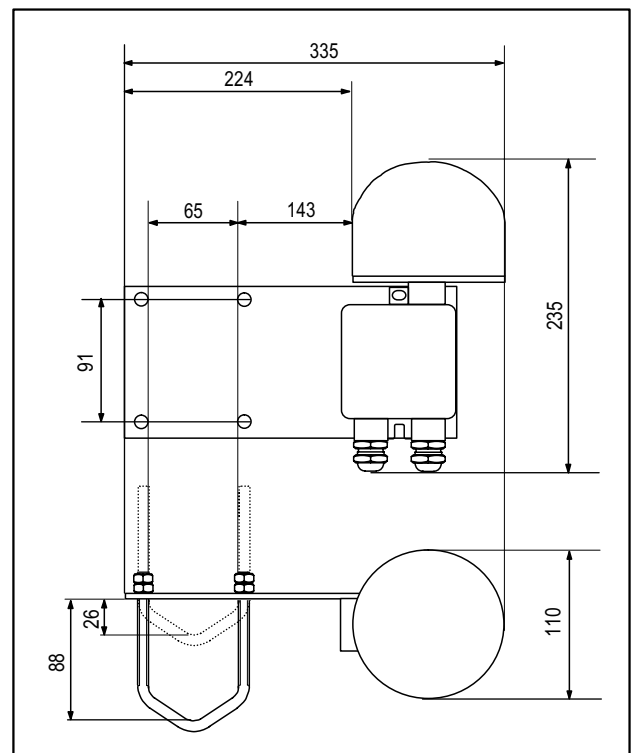

Obelux MS-60 mounting set



Technical information in this document is subject to change without notice. Copyright © Obelux Oy 2010